

# Retarder Prover Room - AVANT

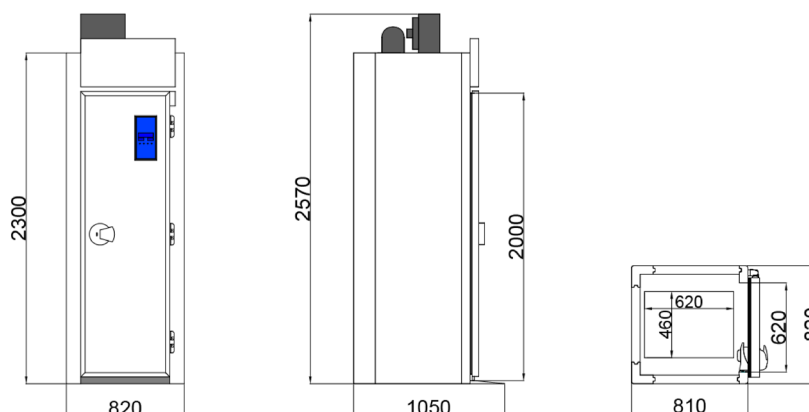

## DATA SHEET

External dimensions	mm 820x810x2300h
Internal dimensions	mm 620x650x1980h
Maximum external height	mm 2600
Structure	Prefabricated modular panels with thickness of insulation 60mm. Polyurethane rigid foam without CFC and density 38/40 Kg/mc. Sanitary profiles on the floor and ceiling
Floor	Without floor
Internal finishing	White painted galvanized sheet
External finishing	White painted galvanized sheet
Doors – entry	n.1 mm 620x2000h – industrial closing
Capacity of racks - trays	n.1 for trays mm 600x400
Evaporator	n.1 with one fan Ø 200mm
Evaporator capacity	600 Watt a 2°C room / -8°C evaporation
Fans absorption	38 Watt
Tropicalized condensing unit	n.1 ermetic Embraco compressor of 1/3Hp with n.1 fan. Dimensions mm 310x470x270h. Pump Down. High and low pressure switch
Condensing unit capacity	669 Watt at -10°C evaporation 38°C condensation
Defrosting resistances	n.1 of 400 Watt
Heating elements	n.1 of 800 Watt
Steam generator	n.1 of 500W S/S - non-water contact resistance
Temperature range	-5 / +40 °C
Humidity range	50 – 100 %
Temperature probe	n.1 Ntc
Humidity probe	n.1 4-20mA
Internal light	no
Avant controller	n.1 Digital with LCD display and 4 programming keys
Voltage	Volt 1x230+N 50Hz
Gas	R452a
Maximum absorption	1,7 Kw.

## OPTIONS

Internal finishing	Stainless steel AISI 304 18/10
External finishing	Stainless steel AISI 304 18/10
External front finishing	Stainless steel AISI 304 18/10
Floor – Version A	Phenolic multilayer wood panel thickness 21mm + s/s ramp
Floor – Version B	Insulated and reinforced floor, thickness of insulation 60mm with exposed phenolic multilayer wood panel + s/s ramp
Floor – Version C	Insulated and reinforced floor, thickness of insulation 60mm with anti-slip stainless steel AISI 304 18/10 finishing + s/s ramp
Remote condensing unit	n.1 Silenced and tropicalized with Embraco compressor of 1Hp + accessories – Volt 1x230+N, 50Hz – distance 10m
Door Glass	Double toughened glass mm 300x300

## CODE

AV62-1P-82x81