

# Retarder Prover Upright - KEY

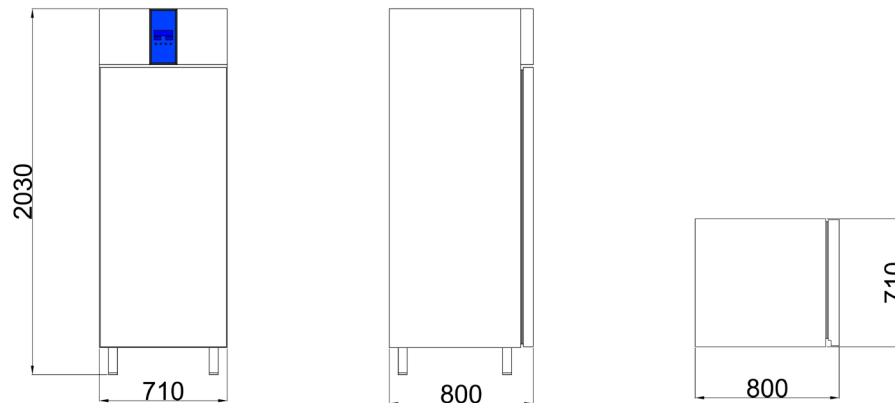

## DATA SHEET

External dimensions	mm 710x800x2030h
Structure	Monoblock with insulation thickness 60mm. insulation by CFC-free rigid polyurethane foam and density 38/40 kg/cm. Lowered bottom for easy cleaning.
Internal finishing	stainless steel AISI 304 18/10
External finishing	Stainless steel AISI 304 18/10 - except bottom, back and technical compartment.
Door	n.1
Capacity of trays	n.20 mm 400x600 - distance between trays mm 62
Evaporator	N. 1 wall mounted with tangential fan
Evaporator capacity	650 Watt at 0°C chamber / -10°C evaporation
Fans absorption	38 Watt
Tropicalized condensing unit	n.1 ermetic Embraco compresor of 1/3 Hp with n.1 condenser fan
Condensing unit capacity	707 Watt at -10°C evaporation / 38°C condensation
Defrosting resistances	n.1 of 400 Watt
Heating elements	n.1 of 800 Watt
Steam generator	n.1 500 Watt s/s, non-water contact resistance
Temperature range	-5 / +40 °C
Humidity range	50 – 100 %
Temperature probe	n.1 Ntc
Humidity probe	n.1 4-20mA
Internal light	Without
Avant controller	n.1 Digital with LCD display and 4 programming keys
Voltage	Volt 1x230+N 50Hz
Gas	R452a
Maximum absorption	1,4 Kw.

## OPTIONS

Door	Glass made with internal led light
------	------------------------------------

## CODE

K20