

Retarder Prover Room - MASTER

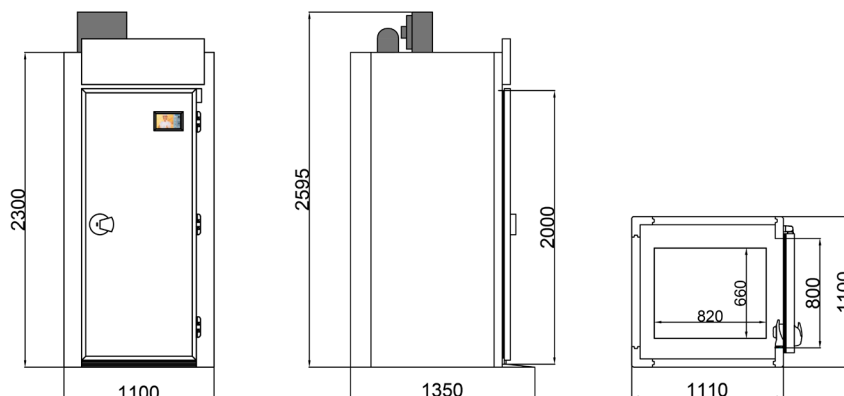

DATA SHEET

External dimensions	mm 1100x1110x2300h
Internal dimensions	mm 800x950x1980h
Maximum external height	mm 2650
Structure	Prefabricated modular panels with thickness of insulation 60mm. Polyurethane rigid foam without CFC and density 38/40 Kg/mc. Sanitary profiles on the floor and ceiling
Floor	Without floor
Internal finishing	White painted galvanized sheet
External finishing	White painted galvanized sheet
Doors – entry	n.1 mm 800x2000h – industrial closing
Capacity of racks - trays	n.1 for trays mm 600x800
Evaporator	n.1 with two fans Ø 200mm
Evaporator capacity	1000 Watt a 2°C room / -8°C evaporation
Fans absorption	76 Watt
Tropicalized condensing unit	n.1 ermetic Embraco compressor of 3/4Hp with n.1 fan. Dimensions mm 360x500x300h. Pump Down. High and low pressure switch
Condensing unit capacity	1020 Watt at -10°C evaporation / 38°C condensation
Defrosting resistances	n.1 of 650 Watt
Heating elements	n.1 of 1000 Watt
Steam generator	n.1 of 500W S/S - non-water contact resistance
Temperature range	-5 / +40 °C
Humidity range	50 – 100 %
Temperature probe	n.1 0-10 Volt
Humidity probe	n.1 0-10 Volt
Internal light	without
Master controller	n.1 electronic with touch screen 7"
Voltage	Volt 1x230+N 50Hz
Gas	R452a
Maximum absorption	1,9 Kw.

OPTIONS

Remote Access	Complete remote room management. E-mail alarms notification.
Internal finishing	Stainless steel AISI 304 18/10
External finishing	Stainless steel AISI 304 18/10
External front finishing	Stainless steel AISI 304 18/10
Floor – Version A	Phenolic multilayer wood panel thickness 21mm + s/s ramp
Floor – Version B	Insulated and reinforced floor, thickness of insulation 60mm with exposed phenolic multilayer wood panel + s/s ramp
Floor – Version C	Insulated and reinforced floor, thickness of insulation 60mm with anti-slip stainless steel AISI 304 18/10 finishing + s/s ramps.
Remote condensing unit	n.1 Silenced and tropicalized with Embraco compressor of 1,1Hp + accessories – Volt 1x230+N, 50Hz – distance 10m
Extra heat function	Activating the extra heat function (700W) in the Manual Proving programme
Door Glass	Double toughened glass mm 300x300

CODE

MA80-1P-110x111