

# Prover Room - START

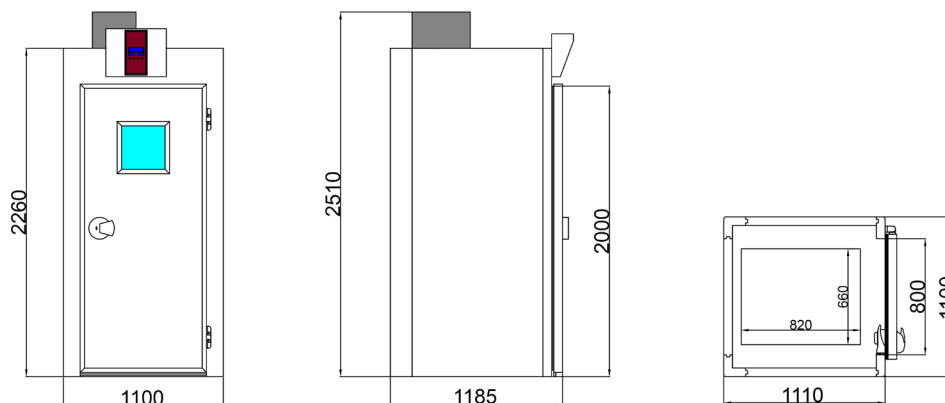

## DATA SHEET

External dimensions	mm 1100x1110x2260h
Internal dimensions	mm 800x990x1950h
Maximum external height	mm 2600
Structure	Prefabricated modular panels with thickness of insulation 60mm. Polyurethane rigid foam without CFC and density 38/40 Kg/mc. Sanitary profiles on the floor and ceiling
Floor	Without floor
Internal finishing	White painted galvanized sheet
External finishing	White painted galvanized sheet
Doors – entry	n.1 mm 800x2000h – industrial closing
Capacity of racks - trays	n.1 for trays mm 600x800
Heating elements	n.1 of 1500 Watt
Steam generator	n.1 of 500 Watt non-water contact resistance
Temperature range	Ambient / +40 °C
Humidity range	Ambient / 100 %
Temperature probe	n.1 Ntc
Humidity probe	n.1 4-20mA
Internal light	n.1 lamp
Avant controller	n.1 Digital with LCD display and 4 programming keys
Voltage	Volt 1x230+N 50Hz
Maximum absorption	2,5 Kw.

## OPTIONS

Internal finishing	Stainless steel AISI 304 18/10
External finishing	Stainless steel AISI 304 18/10
External front finishing	Stainless steel AISI 304 18/10
Floor	Phenolic multilayer wood panel thickness 21mm + s/s ramp

## CODE

ST80-1P-110x111